

VERSA COMMERCIAL
LED DOWNLIGHT



NEW CONSTRUCTION



REMODEL



RETROFIT

SPECIFICATION GRADE COMMERCIAL LED DOWNLIGHT



TABLE OF CONTENTS

Anatomy 4

Application..... 5

Versa Commercial Performance..... 6

- Optical Lenses
- Filters
- Ability to Interchange Optics and Filters
- 2 Step MacAdam Ellipse

Versa Commercial Performance..... 7

- Intelligent Drive
- Emergency Battery
- Color Rendering Index
- Tool-less Interchangeability

4" Versa Commercial..... 8-9

4" Versa Commercial Single Sidekick Wall Wash..... 10

4" Versa Commercial Double Sidekick Wall Wash..... 11

6" Versa Commercial..... 12-13

6" Versa Commercial Single Sidekick Wall Wash..... 14

6" Versa Commercial Double Sidekick Wall Wash..... 15

ANATOMY

THERMAL MANAGEMENT

As the operating temperature of the LED plays a key role on color and lifespan, Rayon Lighting's engineered heat sink spreads heat equally throughout this fine extrusion for enhanced thermal management, operating life, and color consistency.

OPTIC & LENS HOLDER

This unique optic and filter holder enables easy selection of optical lenses and a myriad of filters in order to achieve a particular effect with its tool-less twist lock mechanism. It was designed for fine tuning glare and control of light distribution.

REFLECTOR & TRIM

Interchangeable reflector and trim are available in an assortment of finishes in order to meet a project's specifications. This unique, tool-less design makes specifying and installation easy.

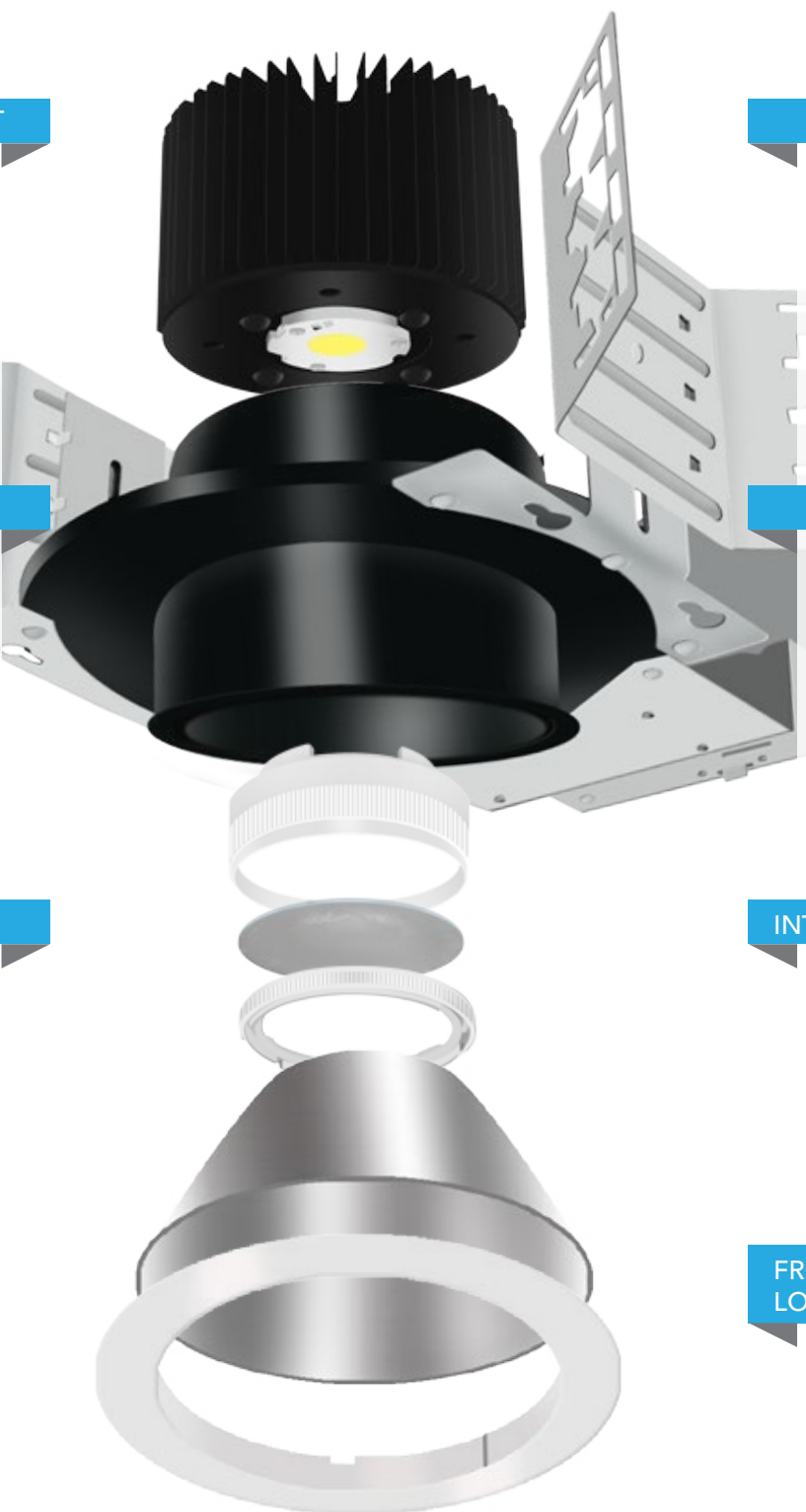

CREE LED

Rayon Lighting's careful selection of Cree LEDs is from a specific bin that exceeds minimum industry standards available in 4 color temperatures (2,700K; 3,000K; 3,500K; 4,000K) and a CRI of 93+. Its binning selection from a 2 Step MacAdam Ellipse ensures even color consistency between fixtures.

INTELLIGENT DRIVE

Intelligent Drive provides a wide array of dimmer compatibility by taking the best from three standard drivers and combining into one. This all-inclusive driver works with 0-10V, Triac, and ELV dimmers allowing for easy specification.

INTERCHANGEABLE OPTICS

Optical lenses are available in 18°, 30°, 50°, and 70° beam angles for easy selection from spot to wide flood distribution. Easy tool-less mechanism allows for interchangeable optics in the field.

FROSTED, HEX CELL LOUVER, AND SOLITE

An assortment of filter options for various applications with tool-less installation.

APPLICATION

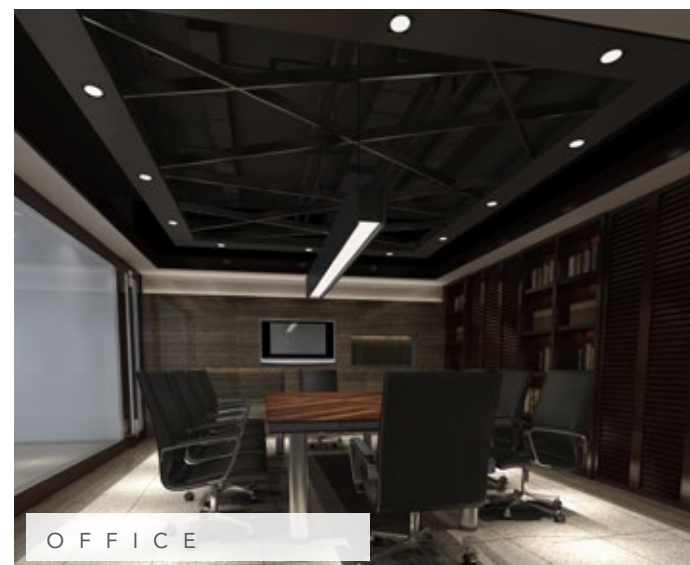

Refer to spec sheet for more information.
Design and specifications are subject to change without notice.

OPTICAL LENS

The Versa Commercial is available in a wide array of optical lenses to meet your projects specifications. Rayon Lighting's optics deliver an impressive level of uniformity in 18°, 30°, 50°, and 70° beam angles.

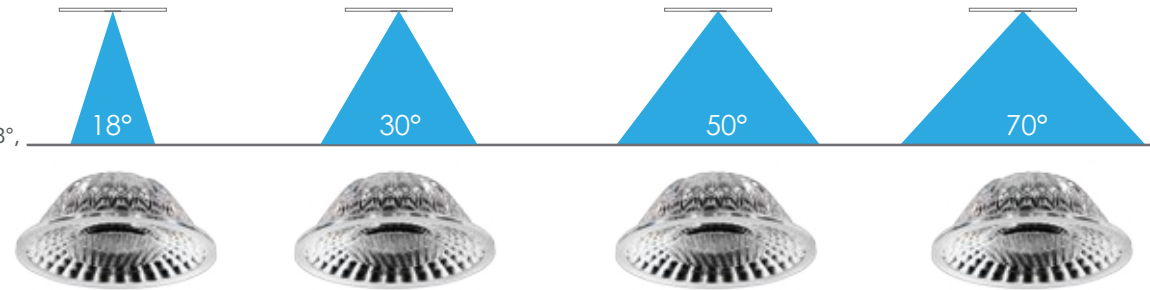

FILTERS

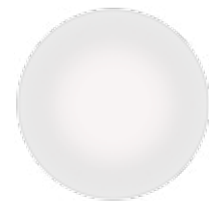

Frosted Filter



Hex Cell Louver



Solite Filter

ABILITY TO INTERCHANGE OPTICS & FILTERS

Utilization of optics and filters enables easy achievement of various light patterns and effects. Rayon Lighting's tool-less system allows for easy design and installation.



2 STEP MacADAM ELLIPSE

Color precision is extremely important to Rayon Lighting. To ensure the highest quality and consistent product performance, Rayon Lighting employs a 2-step binning criteria which provides more accurate results within the CIE chromaticity diagram. What is binning? Binning is a process used by manufacturers to group LEDs for consistency of critical performance attributes such as lumen output and color temperature. Smaller bin sizes maintain a tighter control of the variables.

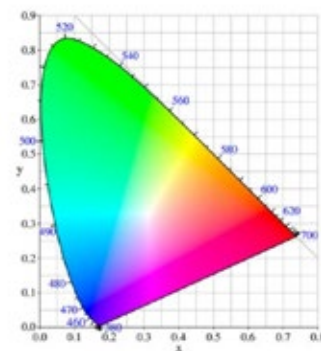

WHAT IS INTELLIGENT DRIVE?

Specifiers, distributors, and installers will consider Intelligent Drive a dynamic system saving time and resources. Intelligent Drive provides a wide array of dimmer compatibility by taking the best from three standard drivers and combining into one. This all-inclusive driver works with 0-10V, Triac, and ELV dimmers making it the ideal choice for specifiers and installers.

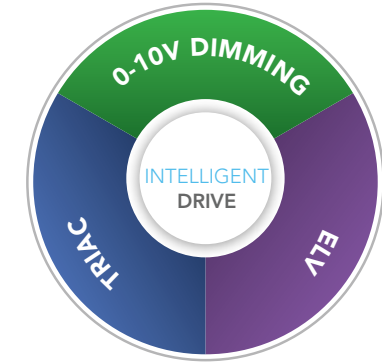

EMERGENCY BATTERY

Optional Emergency Battery available for a minimum of 90 minutes with either integral or remote test switch.

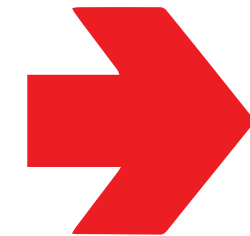

COLOR RENDERING INDEX

The Versa Commercial Series of LED downlights come standard in 93+ CRI. Our R9 value exceeds 60+ allowing faithful reflection of an object's color and a reason to utilize the Versa Commercial Series, particularly in commercial applications where color cannot be compromised.



2700K CRI 70



2700K CRI 93+

TOOL-LESS INTERCHANGEABILITY

VERSA Commercial



Rayon Lighting has engineered a system which allows for tool-less interchangeability of optics, filter accessories, reflectors, and trim. Everything that Rayon Lighting customers are accustomed to since the VersaTrim.



4" NEW CONSTRUCTION

4" REMODEL

4" RETROFIT

4" VERSA COMMERCIAL NON-IC

USE OF PRODUCT

The 4" Versa Commercial LED Downlight is the ideal product for energy efficient lighting in Non-IC New Construction, Remodel and Retrofit commercial applications. Available with interchangeable reflectors and trims, with an assortment of color temperatures, lenses, filters and dimmable driver options.

VERSA COMMERCIAL FEATURES

Wattage	Lumens	Voltage	CRI
15W	1,000 lm	120-277V	93+
21W	1,300 lm	120-277V	93+
29W	1,700 lm	120-277V	93+
38W	2,000 lm	120-277V	93+
28W	2,300 lm	120-277V	93+
36W	2,800 lm	120-277V	93+
43W	3,200 lm	120-277V	93+
55W	4,000 lm	120-277V	93+

*Performance based on 3000K

- Color Temperature: 2700K, 3000K, 3500K, or 4000K
- SDCM: 2 step binning
- Color Rendering Index: 93+ CRI
- R9: 60+
- Optical Lens: 18°, 30°, 50°, 70°
- Filter Accessories: Frosted, hex cell louver, or solite
- LED Life: 50,000 hours
- LED Type: Cree LED
- Versatility: Interchangeable reflector and trim
- Warranty: 5 year limited warranty

LED ENGINE

LED engine available with CREE LEDs in 2700K, 3000K, 3500K, or 4000K in standard 93+ CRI. 2 Step MacAdam ellipse allows for color consistency between fixtures. LED engine is available in a multitude of optical lenses allowing for easy optical control. LED mounted to aluminum heat sink for maximum life output and thermal management.

OPTICAL LENS (Field Replaceable)

Field replaceable optical lens available in 18°, 30°, 50° and 70°. Easily achieve narrow spot to wide flood beam pattern.

FILTER ACCESSORIES:

A multitude of filter accessories are available to achieve a particular light effect. Available in Frosted, Hex Cell louver, or Solite filter options.

DIMMING

Available in 7 driver selections. (ID) Standard all-inclusive ELV, Triac, and 0-10V dimming driver called Intelligent Drive, 120-277V. (L3DEA) Lutron Hi-Lume 1% Ecosystem, 120-277V. (L3D3W) Lutron Hi-Lume 1% 3-wire, 120-277V. (LDEI) Lutron Hi-Lume 1% Ecosystem with soft on, fade to black dimming, 120-277V. (EEI) eldoLED Eco 1% Dim (0-10V), 120-277V. (EDIO) eldoLED Solo .1% Dim(0-10V), 120-277V. (EDID) eldoLED Solo .1% Dim(DALI), 120-277V.

VERSATILITY

The Versa Commercial LED Downlight series provides for interchangeable reflector and trim in round shape with an assortment of finishes to achieve a particular look. The ability to field install and/or replace various reflector, trim, and optical lenses makes the Versa Commercial Downlight Series the most flexible commercial downlight in the industry.

EMERGENCY BATTERY

Optional emergency battery available for a minimum of 90 minutes with both integral or remote test switch.

INSTALLATION:

Non-IC housing. Insulation must be kept at least 3" away from fixture.

LABELS/COMPLIANCE

-CSA Listed for US and Canada

AVAILABLE FINISHES

VERSA COMMERCIAL

A hallmark of Rayon Lighting is our approach to design. The Versa Commercial series allows for great versatility with its ability to interchange various reflector and trim finishes with ease.



ORDER INFORMATION

Series	Lumens	Color Temp	Voltage	Dimming	Optical Distribution
RVC4	28L	35K	UNV	ID	50
RVC4	10L - 1000 lm 13L - 1300 lm 17L - 1700 lm 20L - 2000 lm 23L - 2300 lm 28L - 2800 lm 32L - 3200 lm 40L - 4000 lm	27K - 2700K 30K - 3000K 35K - 3500K 40K - 4000K	UNV - 120-277V 3' - 347V	ID ² - Standard all-inclusive ELV, Triac, and 0-10V dimming driver (Intelligent Drive) L3DAE - Lutron Hi-Lume 1% Ecosystem L3D3W - Lutron Hi-Lume 1% 3-Wire LDEI - Lutron Hi-Lume 1% Ecosystem with soft on, fade to black dimming. EEI ³⁴ - eldoLED Eco 1% Dim (0-10V) EDIO ³⁴ - eldoLED Solo .1% Dim (0-10V) EDID ³⁴ - eldoLED Solo .1% Dim (DALI)	18 - 18° Beam 30 - 30° Beam 50 - 50° Beam 70 - 70° Beam
Reflector	Trim	Frame	Frame Accessories	Options	
4RS	4TW	FN	C ⁵ - C Channel bar hanger B ⁵ - Flat bar hanger WJ ⁵ - Wood joist	E18 - Emergency battery with integral switch (800 Lumens) ER8 - Emergency battery with remote switch (800 Lumens) E117 - Emergency battery with integral switch (1700 Lumens) ER17 - Emergency battery with remote switch (1700 Lumens) WL - Wet location F - Frosted filter H - Hex Cell louver S - Solite filter	
4RW - White 4RS - Specular Clear 4RH - Haze 4RB - Black MTO - Made to order	4TW - White 4TS - Specular Clear 4TH - Haze 4TB - Black MTO - Made to order	FN - New Construction FR - Remodel AC - Retrofit			

1. Step down transformer required.
2. Intelligent Drive is the standard driver for the Versa Commercial.
3. Inapplicable to 4000 Lumen offering.
4. Must specify logarithmic or linear eldoLED driver.
5. Does not apply to remodel & retrofit application.

ORDER INFORMATION EXAMPLE

RVC4-28L-35K-UNV-ID-50-4RS-4TW-FN
(RVC4 - 2800 Lumens - 3500K - UNV(120-277V) - Intelligent Drive - 50° Beam - 4" Reflector specular clear - 4" Trim white - New construction)



4" SINGLE SIDEKICK WALL WASH



4" DOUBLE SIDEKICK WALL WASH



SINGLE SIDEKICK WALL WASH

Use of Product

The Versa Commercial Single Sidekick Wall Wash Series is the ideal product for energy efficient lighting in Non-IC New Construction, Remodel and Retrofit applications where wall washing is required.

Feature

- Versa Commercial Single Sidekick Wall Wash utilizes angle bending diffuser technology that evenly redirects and distributes light for precision wall washing.
- Color Temperature: 2700K, 3000K, 3500K, or 4000K

- SDCM: 2 step binning
- Color Rendering Index: 93+ CRI
- R9: 60+
- Optical Lens: 30°, 50°
- LED Life: 50,000 hours
- LED Type: Cree LED
- Warranty: 5 year limited warranty

Labels/Compliance

- CSA Listed for US and Canada

Single Sidekick Wall Wash

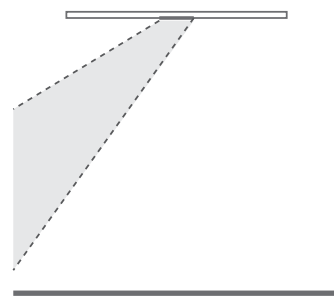

SINGLE SIDEKICK WALL WASH ORDERING INFO

Series	Lumens	Color Temperature	Voltage	Dimming
RVC4SW-30	19L	35K	UNV	ID
RVC4SW-30 - 4" Versa Commercial 30° Single Wall Wash	7L - 700 lm	27K - 2700K	UNV - 120-277V 3' - 347V	ID ² - Standard all-inclusive ELV, Triac, and 0-10V dimming driver (Intelligent Drive) L3DAE - Lutron Hi-Lume 1% Ecosystem L3D3W - Lutron Hi-Lume 1% 3-Wire LDEI - Lutron Hi-Lume 1% Ecosystem with soft on, fade to black dimming. EEI ³ - eldoLED Eco 1% Dim (0-10V) EDIO ^{3A} - eldoLED Solo .1% Dim (0-10V) EDID ^{3A} - eldoLED Solo .1% Dim (DALI)
	9L - 950 lm	30K - 3000K		
	12L - 1200 lm	35K - 3500K		
	14L - 1400 lm	40K - 4000K		
	15L - 1550 lm			
	19L - 1900 lm			
	27L - 2700 lm			
RVC4SW-50 - 4" Versa Commercial 50° Single Wall Wash	6L - 650 lm			
	9L - 900 lm			
	11L - 1150 lm			
	13L - 1300 lm			
	15L - 1500 lm			
	25L - 2500 lm			

DOUBLE SIDEKICK WALL WASH

Use of Product

The Versa Commercial Double Sidekick Wall Wash Series is the ideal product for energy efficient lighting in Non-IC New Construction, Remodel and Retrofit applications where wall washing is required.

Feature

- Versa Commercial Double Sidekick Wall Wash utilizes angle bending diffuser technology that evenly redirects and distributes light for precision wall washing.
- Color Temperature: 2700K, 3000K, 3500K, or 4000K

- SDCM: 2 step binning
- Color Rendering Index: 93+ CRI
- R9: 60+
- Optical Lens: 30°, 50°
- LED Life: 50,000 hours
- LED Type: Cree LED
- Warranty: 5 year limited warranty

Labels/Compliance

- CSA Listed for US and Canada

Double Sidekick Wall Wash

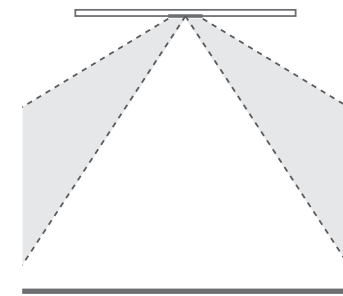

DOUBLE SIDEKICK WALL WASH ORDERING INFO

Series	Lumens	Color Temperature	Voltage	Dimming
RVC4DW-30	9L	35K	UNV	ID
RVC4DW-30 - 4" Versa Commercial 30° Double Wall Wash	7L - 700 lm	27K - 2700K	UNV - 120-277V 3' - 347V	ID ² - Standard all-inclusive ELV, Triac, and 0-10V dimming driver (Intelligent Drive) L3DAE - Lutron Hi-Lume 1% Ecosystem L3D3W - Lutron Hi-Lume 1% 3-Wire LDEI - Lutron Hi-Lume 1% Ecosystem with soft on, fade to black dimming. EEI ³ - eldoLED Eco 1% Dim (0-10V) EDIO ^{3A} - eldoLED Solo .1% Dim (0-10V) EDID ^{3A} - eldoLED Solo .1% Dim (DALI)
	9L - 950 lm	30K - 3000K		
	12L - 1200 lm	35K - 3500K		
	14L - 1400 lm	40K - 4000K		
	15L - 1550 lm			
	19L - 1900 lm			
	27L - 2700 lm			
RVC4DW-50 - 4" Versa Commercial 50° Double Wall Wash	6L - 650 lm			
	9L - 900 lm			
	11L - 1150 lm			
	13L - 1300 lm			
	15L - 1500 lm			
	25L - 2500 lm			

Single Wall Wash Trim	Frame	Frame Accessories	Options
4TWS	FN		
4TWS - White Single Wall Wash	FN - New Construction	C ⁵ - C Channel bar hanger	ER8 - Emergency battery with remote switch (800 Lumens)
4TSS - Specular Clear Single Wall Wash	FR - Remodel	B ⁵ - Flat bar hanger	ER17 - Emergency battery with remote switch (1700 Lumens)
4THS - Haze Single Wall Wash	AC - Retrofit	WJ ⁵ - Wood joist	WL - Wet location
4TBS - Black Single Wall Wash			
MTO - Made to order			

Double Wall Wash Trim	Frame	Frame Accessories	Options
4TWD	FN		
4TWD - White Double Wall Wash	FN - New Construction	C ⁵ - C Channel bar hanger	ER8 - Emergency battery with remote switch (800 Lumens)
4TSD - Specular Clear Double Wall Wash	FR - Remodel	B ⁵ - Flat bar hanger	ER17 - Emergency battery with remote switch (1700 Lumens)
4THD - Haze Double Wall Wash	AC - Retrofit	WJ ⁵ - Wood joist	WL - Wet location
4TBD - Black Double Wall Wash			
MTO - Made to order			

1. Step down transformer required.
2. Intelligent Drive is the standard driver for the Versa Commercial.
3. Inapplicable to 2700 Lumen offering.
4. Does not apply to remodel & retrofit application.
5. Must specify logarithmic or linear eldoLED diver.

1. Step down transformer required.
2. Intelligent Drive is the standard driver for the Versa Commercial.
3. Inapplicable to 2700 Lumen offering.
4. Must specify logarithmic or linear eldoLED diver.
5. Does not apply to remodel & retrofit application.



AVAILABLE FINISHES

VERSA COMMERCIAL

A hallmark of Rayon Lighting is our approach to design. The Versa Commercial series allows for great versatility with its ability to interchange various reflector and trim finishes with ease.

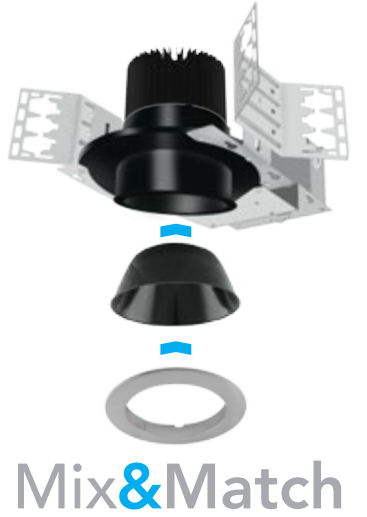

6" VERSA COMMERCIAL NON-IC

USE OF PRODUCT

The 6" Versa Commercial LED Downlight is the ideal product for energy efficient lighting in Non-IC New Construction, Remodel and Retrofit commercial applications. Available with interchangeable reflectors and trims, with an assortment of color temperatures, lenses, filters and dimmable driver options.

LED ENGINE

LED engine available with CREE LEDs in 2700K, 3000K, 3500K, or 4000K in standard 93+ CRI. 2 Step MacAdam ellipse allows for color consistency between fixtures. LED engine is available in a multitude of optical lenses allowing for easy optical control. LED mounted to aluminum heat sink for maximum life output and thermal management.

VERSATILITY

The Versa Commercial LED Downlight series provides for interchangeable reflector and trim in round shape with an assortment of finishes to achieve a particular look. The ability to field install and/or replace various reflector, trim, and optical lenses makes the Versa Commercial Downlight Series the most flexible commercial downlight in the industry.

VERSA COMMERCIAL FEATURES

Wattage	Lumens	Voltage	CRI
15W	1,000 lm	120-277V	93+
21W	1,300 lm	120-277V	93+
29W	1,700 lm	120-277V	93+
38W	2,000 lm	120-277V	93+
28W	2,300 lm	120-277V	93+
36W	2,800 lm	120-277V	93+
43W	3,200 lm	120-277V	93+
55W	4,000 lm	120-277V	93+

*Performance based on 3000K

- Color Temperature: 2700K, 3000K, 3500K, or 4000K
- SDCM: 2 step binning
- Color Rendering Index: 93+ CRI
- R9: 60+
- Optical Lens: 18°, 30°, 50°, 70°
- Filter Accessories: Frosted, hex cell louver, or solite
- LED Life: 50,000 hours
- LED Type: Cree LED
- Versatility: Interchangeable reflector and trim
- Warranty: 5 year limited warranty

OPTICAL LENS (Field Replaceable)

Field replaceable optical lens available in 18°, 30°, 50° and 70°. Easily achieve narrow spot to wide flood beam pattern.

FILTER ACCESSORIES:

A multitude of filter accessories are available to achieve a particular light effect. Available in Frosted, Hex Cell louver, or Solite filter options.

DIMMING

Available in 7 driver selections. **(ID)** Standard all-inclusive ELV, Triac, and 0-10V dimming driver called Intelligent Drive, 120-277V. **(L3DEA)** Lutron Hi-Lume 1% Ecosystem, 120-277V. **(L3D3W)** Lutron Hi-Lume 1% 3-wire, 120-277V. **(LDEI)** Lutron Hi-Lume 1% Ecosystem with soft on, fade to black dimming, 120-277V. **(EEI)** eldoLED Eco 1% Dim (0-10V), 120-277V. **(EDIO)** eldoLED Solo .1% Dim(0-10V), 120-277V. **(EDID)** eldoLED Solo .1% Dim(DALI), 120-277V.

EMERGENCY BATTERY

Optional emergency battery available for a minimum of 90 minutes with both integral or remote test switch.

INSTALLATION:

Non-IC housing. Insulation must be kept at least 3" away from fixture.

LABELS/COMPLIANCE

-CSA Listed for US and Canada

ORDER INFORMATION

Series	Lumens	Color Temp	Voltage	Dimming	Optical Distribution
RVC6	32L	40K	UNV	ID	18
RVC6	10L - 1000 lm 13L - 1300 lm 17L - 1700 lm 20L - 2000 lm 23L - 2300 lm 28L - 2800 lm 32L - 3200 lm 40L - 4000 lm	27K - 2700K 30K - 3000K 35K - 3500K 40K - 4000K	UNV - 120-277V 3' - 347V	ID² - Standard all-inclusive ELV, Triac, and 0-10V dimming driver (Intelligent Drive) L3DAE - Lutron Hi-Lume 1% Ecosystem L3D3W - Lutron Hi-Lume 1% 3-Wire LDEI - Lutron Hi-Lume 1% Ecosystem with soft on, fade to black dimming. EEI³ - eldoLED Eco 1% Dim (0-10V) EDIO^{3,4} - eldoLED Solo .1% Dim (0-10V) EDID^{3,4} - eldoLED Solo .1% Dim (DALI)	18 - 18° Beam 30 - 30° Beam 50 - 50° Beam 70 - 70° Beam
Reflector	Trim	Frame	Frame Accessories	Options	
6RB	6TW	FN			
6RW - White 6RS - Specular Clear 6RH - Haze 6RB - Black MTO - Made to order	6TW - White 6TS - Specular Clear 6TH - Haze 6TB - Black MTO - Made to order	FN - New Construction FR - Remodel AC - Retrofit	C⁵ - C Channel bar hanger B⁵ - Flat bar hanger WJ⁵ - Wood joist	E18 - Emergency battery with integral switch (800 Lumens) ER8 - Emergency battery with remote switch (800 Lumens) E17 - Emergency battery with integral switch (1700 Lumens) ER17 - Emergency battery with remote switch (1700 Lumens) WL - Wet location F - Frosted filter H - Hex Cell louver S - Solite filter	

1. Step down transformer required.
2. Intelligent Drive is the standard driver for the Versa Commercial.
3. Inapplicable to 4000 Lumen offering.
4. Must specify logarithmic or linear eldoLED driver.
5. Does not apply to remodel & retrofit application.

ORDER INFORMATION EXAMPLE

RVC6-32L-40K-UNV-ID-18-6RB-6TW-FN
(RVC6 - 3200lm - 4000K - UNV(120-277V) - Intelligent Drive - 18° Beam - 6" Reflector black - 6" Trim white - New Construction)



6" SINGLE SIDEKICK WALL WASH



6" DOUBLE SIDEKICK WALL WASH



SINGLE SIDEKICK WALL WASH

Use of Product

The Versa Commercial Single Sidekick Wall Wash Series is the ideal product for energy efficient lighting in Non-IC new construction, remodel and retrofit applications where wall washing is required.

Feature

- Versa Commercial Single Sidekick Wall Wash utilizes angle bending diffuser technology that evenly redirects and distributes light for precision wall washing.
- Color Temperature: 2700K, 3000K, 3500K, or 4000K

- SDCM: 2 step binning
- Color Rendering Index: 93+ CRI
- R9: 60+
- Optical Lens: 30°, 50°
- LED Life: 50,000 hours
- LED Type: Cree LED
- Warranty: 5 year limited warranty

Labels/Compliance

- CSA Listed for US and Canada

Single Sidekick Wall Wash

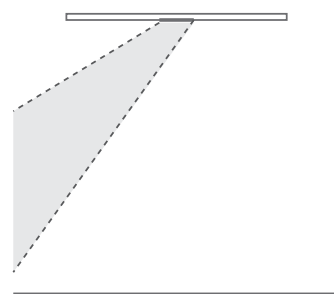

SINGLE SIDEKICK WALL WASH ORDERING INFO

Series	Lumens	Color Temperature	Voltage	Dimming
RVC6SW-30	14L	35K	UNV	ID
RVC6SW-30 - 6" Versa Commercial 30° Single Wall Wash	7L - 700 lm	27K - 2700K	UNV - 120-277V 3' - 347V	ID ² - Standard all-inclusive ELV, Triac, and 0-10V dimming driver (Intelligent Drive) L3DAE- Lutron Hi-Lume 1% Ecosystem L3D3W- Lutron Hi-Lume 1% 3-Wire LDEI- Lutron Hi-Lume 1% Ecosystem with soft on, fade to black dimming. EEI ³ - eldoLED Eco 1% Dim (0-10V) EDIO ^{3,4} - eldoLED Solo .1% Dim (0-10V) EDID ^{3,4} - eldoLED Solo .1% Dim (DALI)
	9L - 950 lm	30K - 3000K		
	12L - 1200 lm	35K - 3500K		
	14L - 1400 lm	40K - 4000K		
	15L - 1550 lm			
	19L - 1900 lm			
	22L - 2240 lm			
27L - 2700 lm				
RVC6SW-50 - 6" Versa Commercial 50° Single Wall Wash	6L - 650 lm			
	9L - 900 lm			
	11L - 1150 lm			
	13L - 1300 lm			
	15L - 1500 lm			
	25L - 2500 lm			

DOUBLE SIDEKICK WALL WASH

Use of Product

The Versa Commercial Double Sidekick Wall Wash Series is the ideal product for energy efficient lighting in Non-IC new construction, remodel and retrofit applications where wall washing is required.

Feature

- Versa Commercial Double Sidekick Wall Wash utilizes angle bending diffuser technology that evenly redirects and distributes light for precision wall washing.
- Color Temperature: 2700K, 3000K, 3500K, or 4000K

- SDCM: 2 step binning
- Color Rendering Index: 93+ CRI
- R9: 60+
- Optical Lens: 30°, 50°
- LED Life: 50,000 hours
- LED Type: Cree LED
- Warranty: 5 year limited warranty

Labels/Compliance

- CSA Listed for US and Canada

Double Sidekick Wall Wash

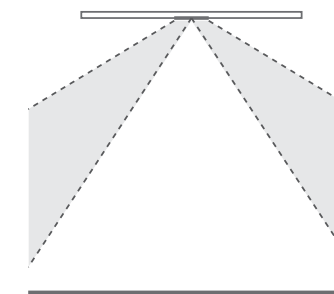

DOUBLE SIDEKICK WALL WASH ORDERING INFO

Series	Lumens	Color Temperature	Voltage	Dimming
RVC6DW-30	27L	35K	UNV	ID
RVC6DW-30 - 6" Versa Commercial 30° Double Wall Wash	7L - 700 lm	27K - 2700K	UNV - 120-277V 3' - 347V	ID ² - Standard all-inclusive ELV, Triac, and 0-10V dimming driver (Intelligent Drive) L3DAE- Lutron Hi-Lume 1% Ecosystem L3D3W- Lutron Hi-Lume 1% 3-Wire LDEI- Lutron Hi-Lume 1% Ecosystem with soft on, fade to black dimming. EEI ³ - eldoLED Eco 1% Dim (0-10V) EDIO ^{3,4} - eldoLED Solo .1% Dim (0-10V) EDID ^{3,4} - eldoLED Solo .1% Dim (DALI)
	9L - 950 lm	30K - 3000K		
	12L - 1200 lm	35K - 3500K		
	14L - 1400 lm	40K - 4000K		
	15L - 1550 lm			
	19L - 1900 lm			
	22L - 2240 lm			
27L - 2700 lm				
RVC6DW-50 - 6" Versa Commercial 50° Double Wall Wash	6L - 650 lm			
	9L - 900 lm			
	11L - 1150 lm			
	13L - 1300 lm			
	15L - 1500 lm			
	25L - 2500 lm			

Single Wall Wash Trim	Frame	Frame Accessories	Options
6TWS	FN		
6TWS - White Single Wall Wash	FN - New Construction	C ⁵ - C Channel bar hanger	ER8 - Emergency battery with remote switch (800 Lumens)
6TSS - Specular Clear Single Wal Wash	FR - Remodel	B ⁵ - Flat bar hanger	ER17 - Emergency battery with remote switch (1700 Lumens)
6THS - Haze Single Wall wash	AC - Retrofit	WJ ⁵ - Wood joist	WL - Wet location
6TBS - Black Single Wall wash			
MTO - Made to order			

Double Wall Wash Trim	Frame	Frame Accessories	Options
6TWD	FN	AH	
6TWD - White Double Wall Wash	FN - New Construction	C ⁵ - C Channel bar hanger	ER8 - Emergency battery with remote switch (800 Lumens)
6TSD - Specular Clear Double Wall Wash	FR - Remodel	B ⁵ - Flat bar hanger	ER17 - Emergency battery with remote switch (1700 Lumens)
6THD - Haze Double Wall Wash	AC - Retrofit	WJ ⁵ - Wood joist	WL - Wet location
6TBD - Black Double Wall Wash			
MTO - Made to order			

1. Step down transformer required.
2. Intelligent Drive is the standard driver for the Versa Commercial.
3. Inapplicable to 2700 Lumen offering.
4. Must specify logarithmic or linear eldoLED driver.
5. Does not apply to remodel & retrofit application.

1. Step down transformer required.
2. Intelligent Drive is the standard driver for the Versa Commercial.
3. Inapplicable to 2700 Lumen offering.
4. Must specify logarithmic or linear eldoLED driver.
5. Does not apply to remodel & retrofit application.



Refer to spec sheet for more information.
Design and specifications are subject to change without notice.

VERSA COMMERCIAL

LED DOWNLIGHT



www.rayonlighting.com

Product Guide Disclaimer

The Information in this guide is for informational purposes only and is subject to change without notice. Consult factory for exact product specifications and/or certifications. Please check our website for most recent changes and updates reflecting our policies and products.
